

### KWVE30-B-SL [↗](#)

循环球轴承滑块

滑块 KWVE..-B-SL, 窄长型滑块, 四列

### 技术信息

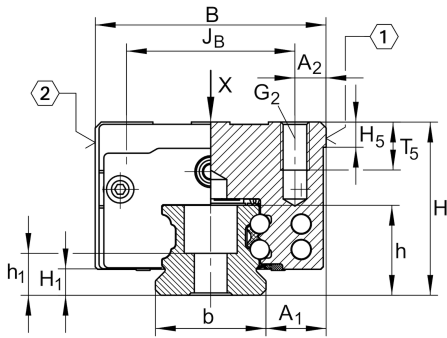

#### 主要尺寸和性能数据

H	42 mm	height system
B	60 mm	width carriage
L	127 mm	overall length carriage
C	34,500 N	dynamic load rating
C <sub>0</sub>	74,000 N	static load rating
M <sub>0x</sub>	1,310 Nm	static moment rating about X axis
M <sub>0y</sub>	1,240 Nm	static moment rating about Y axis
M <sub>0z</sub>	1,240 Nm	static moment rating about Z axis
≈m	1.7 kg	重量

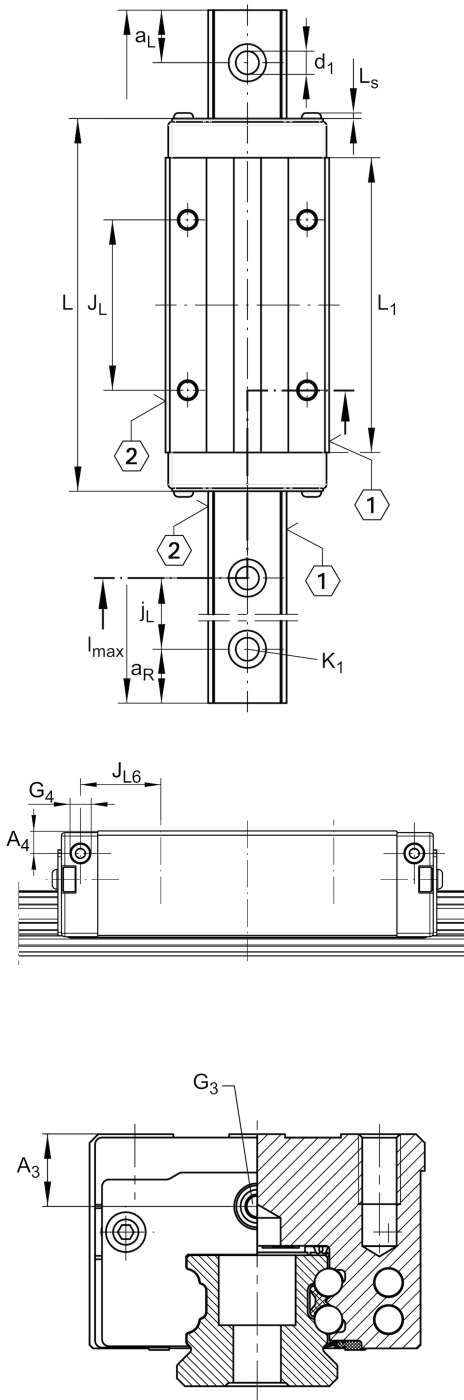

安装尺寸

$A_1$	16 mm	Distance from locating edge on carriage to locating edge on guideway
$J_B$	40 mm	
$b$	28 mm	width rail
$A_2$	10 mm	Distance from locating edge to hole
$L_1$	100 mm	
$L_S$	1.65 mm	
$J_L$	60 mm	
$H_1$	5.9 mm	Free space, system dimension
$H_5$	6.25 mm	
$T_5$	13.5 mm	Thread depth
$G_2$	M8	fixing screws above (DIN ISO 4762-12.9)
$G_2 M_A$	41 Nm	maximum tightening torque
$A_3$	11.5 mm	position lubrication connector
$G_3$	M6	lubrication connector
$t_{G_3}$	7 mm	maximum permissible screw depth for lubrication connectors
$A_4$	7 mm	position lubrication connector
$G_4$	M6	lubrication connector
$t_{G_4}$	7 mm	maximum permissible screw depth for lubrication connectors
$J_{L6}$	25.5 mm	position lubrication connector

附加信息

VMKB_065	KWVE	Material name
----------	------	---------------

