

KWVE35-B-N [↗](#)

循环球轴承滑块

滑块 KWVE..-B-N, 低型滑块, 四列

技术信息

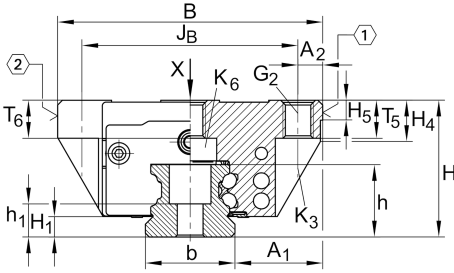

主要尺寸和性能数据

H	44 mm	height system
B	100 mm	width carriage
L	112 mm	overall length carriage
C	38,000 N	dynamic load rating
C ₀	72,000 N	static load rating
M _{0x}	1,465 Nm	static moment rating about X axis
M _{0y}	1,020 Nm	static moment rating about Y axis
M _{0z}	1,020 Nm	static moment rating about Z axis
≈m	1.56 kg	重量



安装尺寸

A_1	33 mm	Distance from locating edge on carriage to locating edge on guideway
J_B	82 mm	
b	34 mm	width rail
A_2	9 mm	Distance from locating edge to hole
L_1	80 mm	
L_S	1.65 mm	
J_L	62 mm	
J_{LZ}	52 mm	
H_1	6.7 mm	Free space, system dimension
H_4	10.3 mm	
H_5	6.75 mm	
T_5	13 mm	Thread depth
T_6	8.3 mm	
G_2	M10	fixing screws above (DIN ISO 4762-12.9)
$G_2 M_A$	41 Nm	maximum tightening torque
K_3	M8	fixing screws below (DIN ISO 4762-12.9)
$K_3 M_A$	41 Nm	maximum tightening torque
K_6	M8	fixing screws below (DIN 7984-8.8)
$K_6 M_A$	12 Nm	maximum tightening torque
D_2	8.6 mm	
A_3	8.3 mm	position lubrication connector
G_3	M6	lubrication connector
t_{G_3}	7 mm	maximum permissible screw depth for lubrication connectors
A_4	7 mm	position lubrication connector
G_4	M6	lubrication connector
t_{G_4}	7 mm	maximum permissible screw depth for lubrication connectors
J_{L6}	16 mm	position lubrication connector

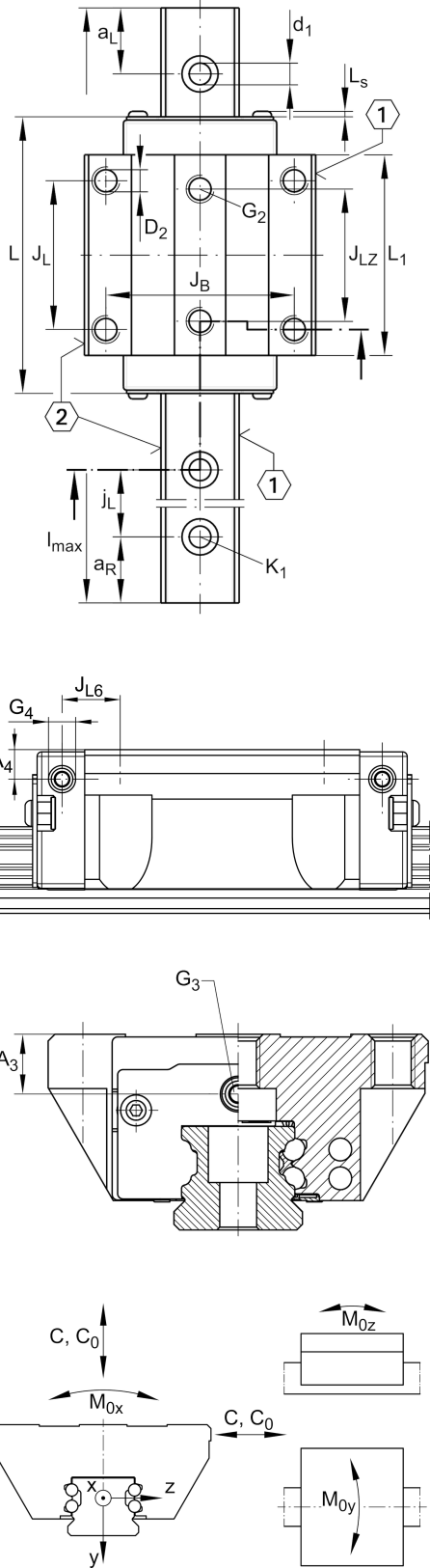



附加信息

VMKB_065	KWVE	Material name
----------	------	---------------

