

KWSE45

循环球轴承滑块

六列直线循环滚珠轴承的标准滑块和导轨组件

X-life

技术信息

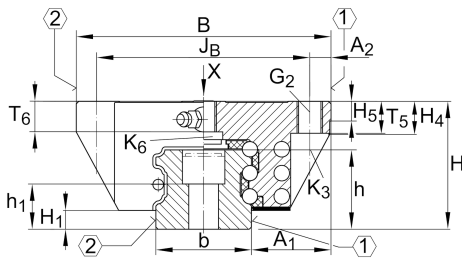

主要尺寸和性能数据

H	60 mm	height system
B	120 mm	width carriage
L	138.7 mm	overall length carriage
I C	80,000 N	dynamic load rating, load direction I: compressive load
I C ₀	174,000 N	static load rating, load direction I: compressive load
II C	72,300 N	dynamic load rating, load direction II: tensile load
II C ₀	117,400 N	static load rating, load direction II: tensile load
III C	76,900 N	dynamic load rating; basic dynamic load rating, Load direction III: lateral load
III C ₀	121,800 N	static load rating, Load direction III: lateral load
≈m	3.15 kg	重量



安装尺寸

A_1	37.5 mm	Distance from locating edge on carriage to locating edge on guideway
J_B	100 mm	
b	45 mm	width rail
A_2	10 mm	Distance from locating edge to hole
L_1	103.1 mm	
J_L	80 mm	
J_{LZ}	60 mm	
H_1	8.6 mm	Free space, system dimension
H_4	17.7 mm	
H_5	9 mm	
T_5	15 mm	Thread depth
T_6	15 mm	
G_2	M12	fixing screws below (DIN ISO 4762-12.9)
$G_2 M_A$	83 Nm	maximum tightening torque
K_3	M10	fixing screws below (DIN ISO 4762-12.9)
$K_3 M_A$	83 Nm	maximum tightening torque
K_6	M10	fixing screws below (DIN ISO 4762-12.9)
$K_6 M_A$	48 Nm	maximum tightening torque
D_2	10.6 mm	
N_2	6 mm	max. diameter of lubrication hole in adjacent construction
J_{L5}	15.65 mm	position lubrication connector
A_3	8.5 mm	position lubrication connector
t_{A_3}	7 mm	maximum permissible screw depth for lubrication connectors
O	7x1,5	O-Ring DIN 3771
M_{0x}	4,500 Nm	Moment
M_{0y}	2,280 Nm	Moment
M_{0z}	2,050 Nm	Moment

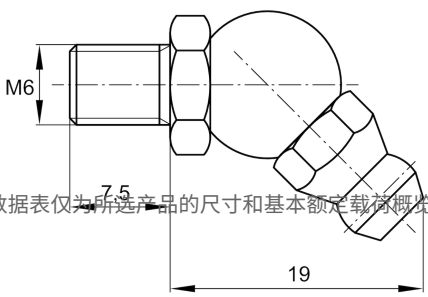
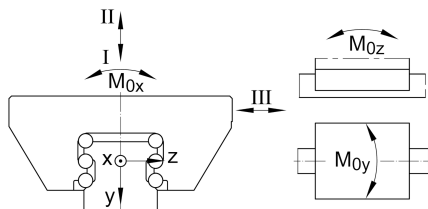
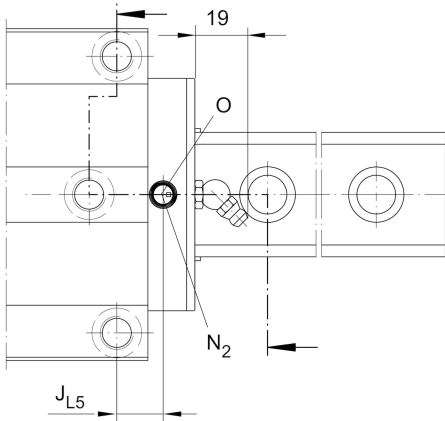
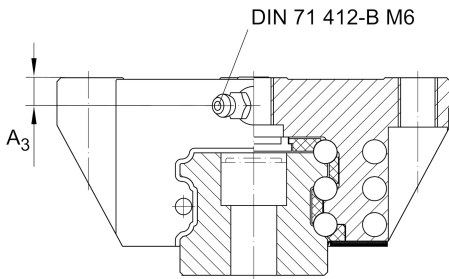
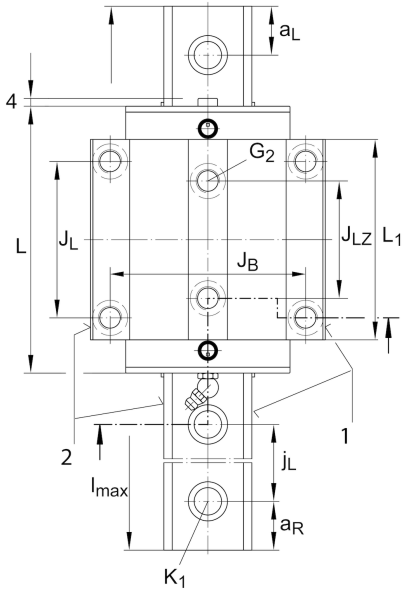



附加信息

VMKB_065

KWSE

Material name